

Aronson

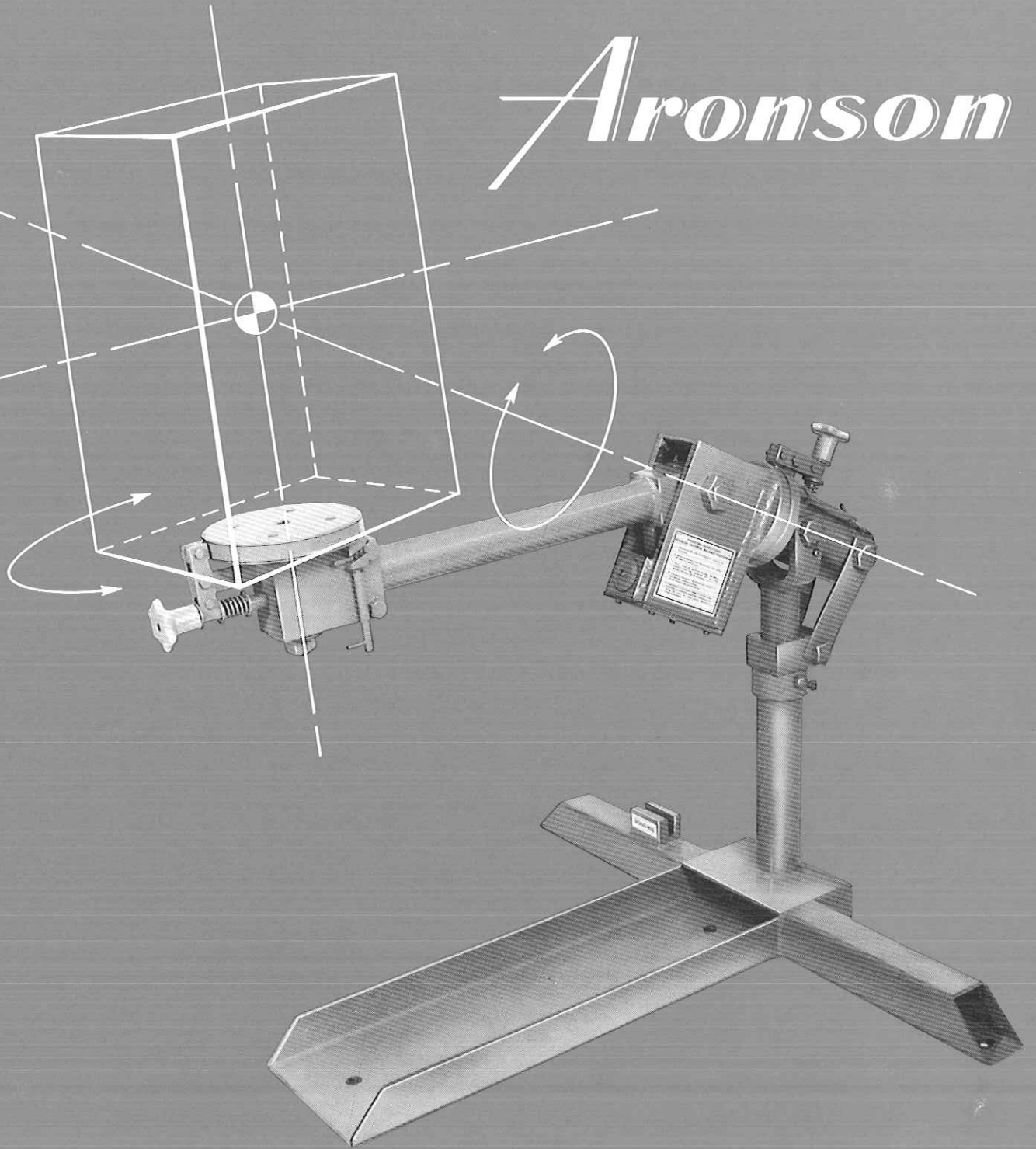

**Universal Balance[®]
POSITIONERS**



www.SterlingMachinery.com Bulletin UB80

Aronson Universal Balance[®] Positioners

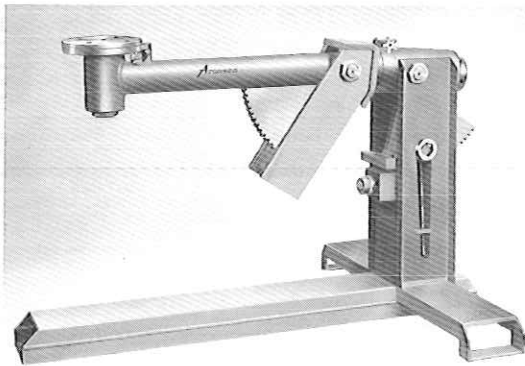
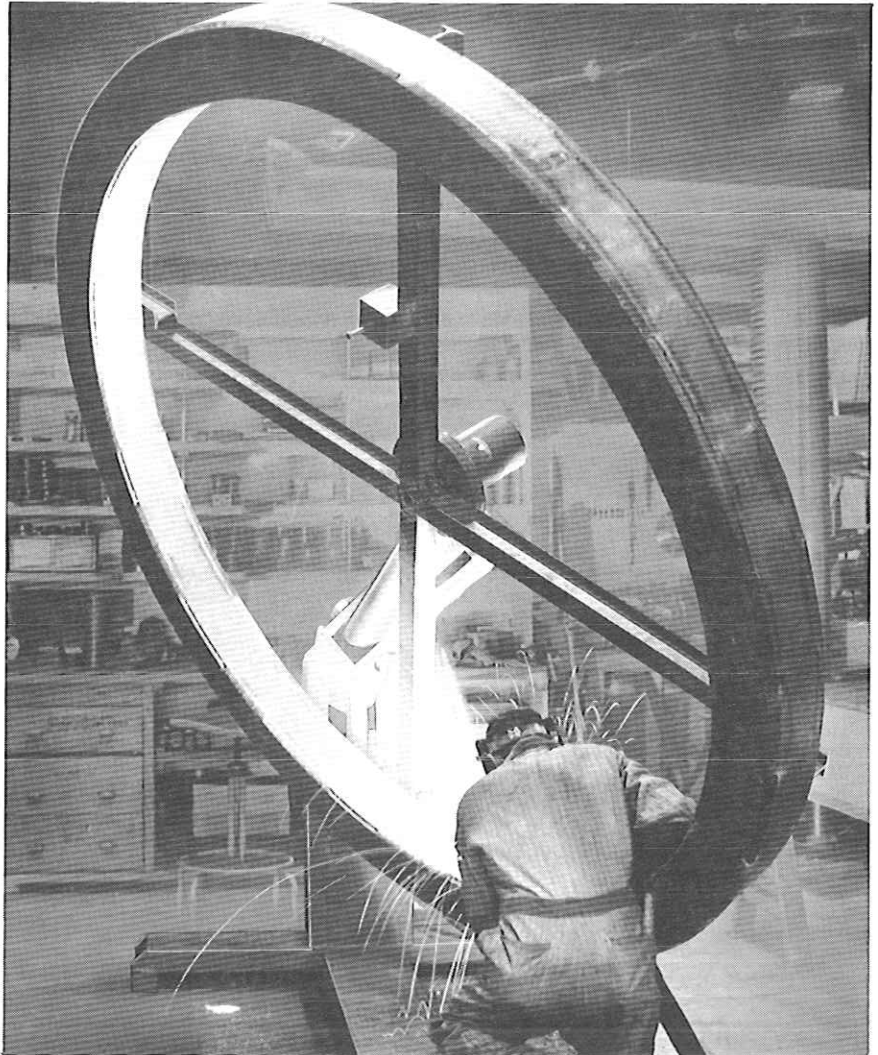

The photograph above shows how one eastern manufacturer uses the Aronson Universal Balance Positioner to make easy work of an awkward welding assembly. This 2,000 pound, 99 inch orbiting ring requires just one set up on Universal Balance as compared to several complete setups by any other means. The result is considerable savings in time and labor. In addition Universal Balance provides 100% accessibility and finger tip control, allowing the weldor to balance the welds while welding in the most efficient down hand position. The bonus result here, is improved quality of welds while requiring far less production time.

ARONSON MACHINE CO. ARCADE, NEW YORK 14009 / Phone (716) 492-2400
 www.SterlingMachinery.com

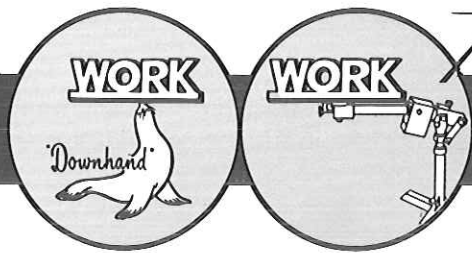

Aronson

SPECIAL UTILITY POSITIONERS

... OFFER INCREASED WELD PRODUCTION,
IMPROVED WELD QUALITY, UNLIMITED ACCESSIBILITY

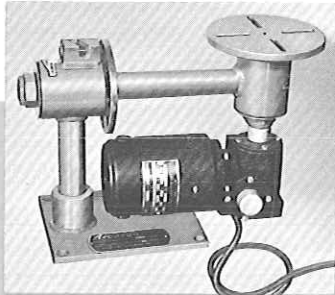

B50P Powered Bench Positioner
(Section 110) CAPACITY 50 LBS.

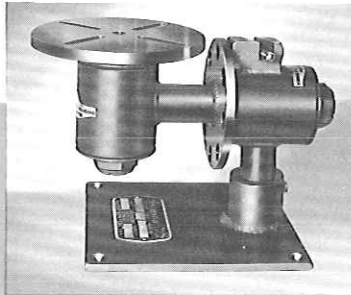

B75 Bench Mount Positioner
(Section 110) CAPACITY 75 LBS.

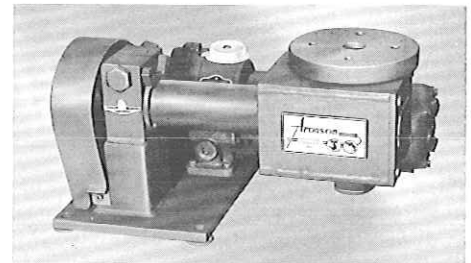

B100PG Powered Bench Positioner (Section 110)
B100P40 CAPACITY 100 LBS.
B100P100

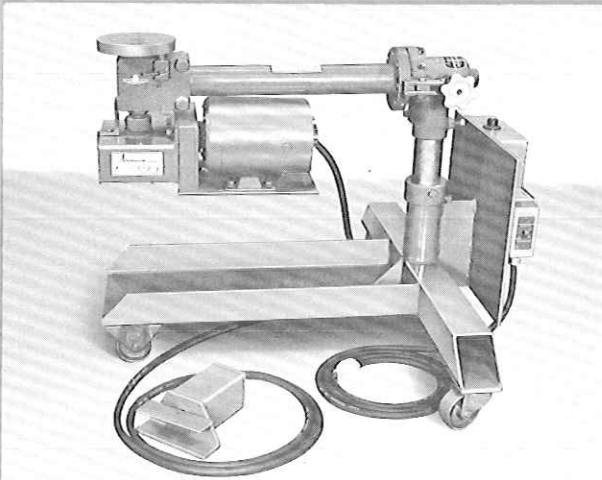

AW300A Automatic Welding Positioner (Section 110)
AW300B CAPACITY 300 LBS.

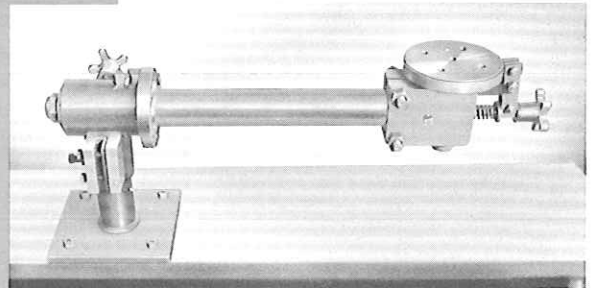

B200 Bench Mount Positioner (Section 110)
CAPACITY 200 LBS.
B200P40 Powered Rotation (Section 110)
B200P100 CAPACITY 200 LBS.

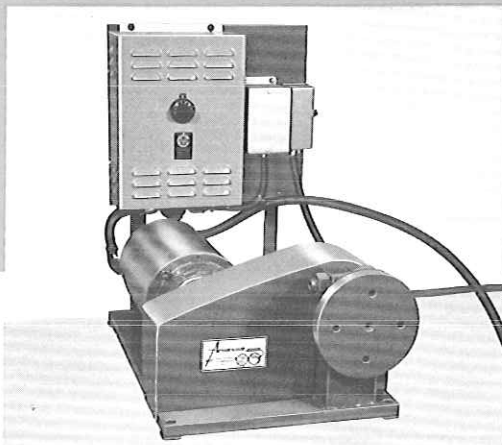

BT500HSA, BT500HSB Bench Headstock (Section 120)
BT500HSC, BT500HSD CAPACITY 500 LBS.

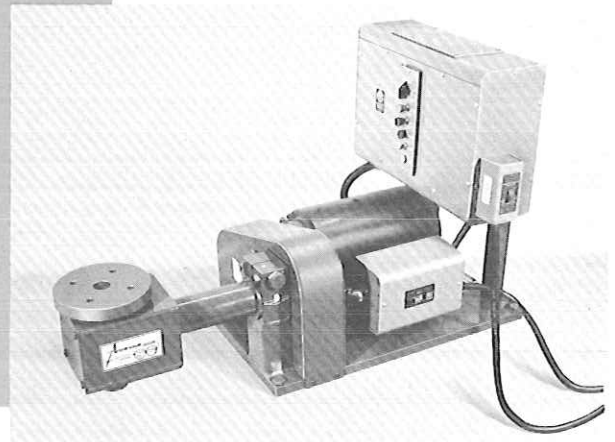

BT500A Bench Turntable Positioner (Section 120)
BT500B CAPACITY 500 LBS.
BT500C Bench Turntable Positioner (Section 120)
BT500D CAPACITY 500 LBS.

Aronson
Sterling
MACHINERY EXCHANGE

COMPANY • ARCADE, NEW YORK 14009
www.SterlingMachinery.com

BENCH HEADSTOCK POSITIONERS

The Series BT500 HS Bench Headstock Positioners are modifications of the proven BT Bench Turntables. They find ideal application where single action, axis horizontal, adjustable speed rotation is required. Used successfully for all welding processes, with the work attached directly to the table, or long work supported by your idler tailstock. Especially suited to hard-facing and metal spraying work.

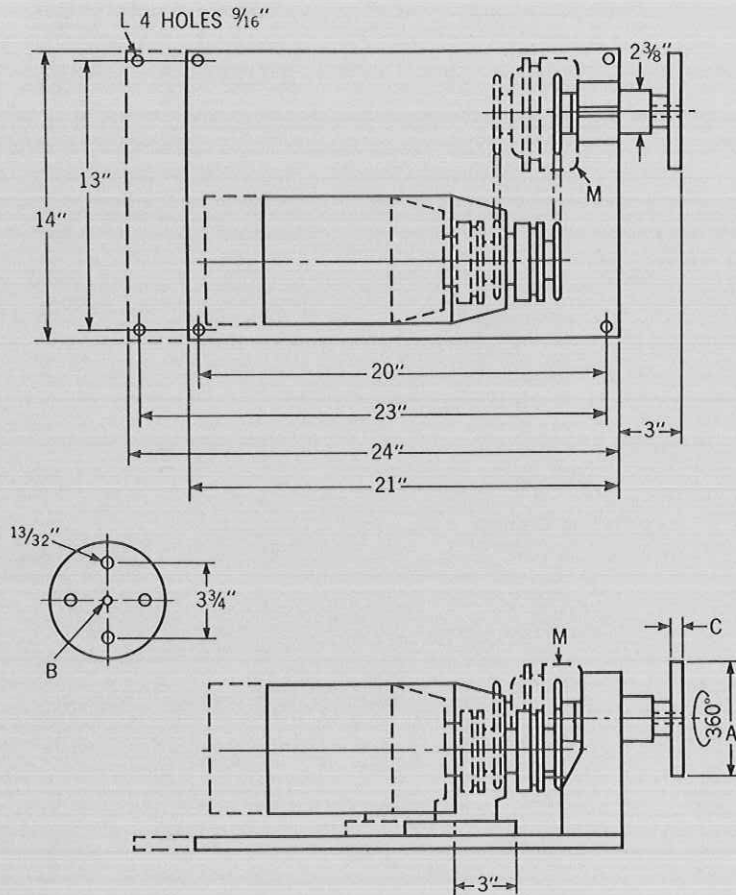
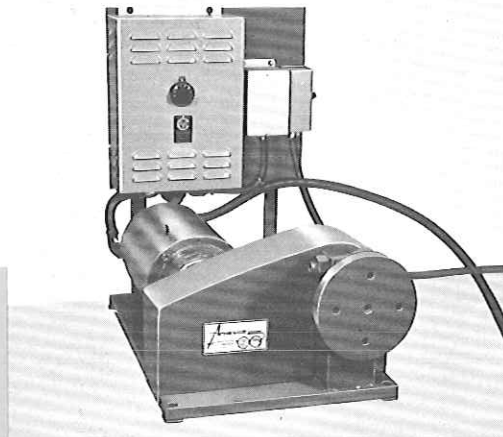

BT500HSA: 500 lbs. @ 12" CG Overhang. 6" 4-hole Table, 6 5/16" CL Height; Two double-row Ball-Bearing Spindle; 500 amps safe weld current conduction. 30 to .75 rpm @ 400 Lbln Torque, 1/4 hp 40:1 SCR DC, dynamic braking, 1-Turn Potentiometer in cabinet, 115/1/60.

BT500HSB: 500 lbs. @ 12" CG Overhang. 6" 4-hole Table, 6 5/16" CL Height; Two double-row Ball-Bearing Spindle; 500 amps safe weld current conduction. 30 to .30 rpm @ 400 Lbln Torque, 1/4 hp 100:1 SCR DC, dynamic braking, 10-Turn Helipot in cabinet, 115/1/60.

BT500HSC: 500 lbs. @ 12" CG Overhang. 6" 4-hole Table, 6 5/16" CL Height; Two double-row Ball-Bearing Spindle; 500 amps safe weld current conduction. INSTANT START-STOP Electric Clutch. 30 to .75 rpm @ 400 Lbln Torque, 1/4 hp 40:1 SCR DC, dynamic braking, 1-Turn Potentiometer in cabinet, 115/1/60.

BT500HSD: 500 lbs. @ 12" CG Overhang. 6" 4-hole Table, 6 5/16" CL Height; Two double-row Ball-Bearing Spindle; 500 amps safe weld current conduction. INSTANT START-STOP Electric Clutch. 30 to .30 rpm @ 400 Lbln Torque, 1/4 hp 100:1 SCR DC, dynamic braking, 10-Turn Helipot in cabinet, 115/1/60.

See Pages 120-6 and 120-7 for OPTIONAL EXTRAS.

Specifications	BT500HSA	BT500HSB	BT500HSC	BT500HSD
LOAD CAPACITY	500 Lbs.	500 Lbs.	500 Lbs.	500 Lbs.
Speed Range, RPM	30-.75	30-.30	30-.75	30-.30
Torque, Lbln	400	400	400	400
"A" Table Diameter	6" 4-hole	6" 4-hole	6" 4-hole	6" 4-hole
"B" Tapped Hole	1/2"-13	1/2"-13	1/2"-13	1/2"-13
"C" Table Thickness	3/4"	3/4"	3/4"	3/4"
"M" Warner Clutch?	No	No	Yes	Yes
Safe Ground Current	500 Amps	500 Amps	500 Amps	500 Amps

Aronson MACHINE COMPANY • ARCADE, N. Y. 14009 • Phone 716-492-2400

Authorized Aronson Representative



www.SterlingMachinery.com