

ACCU II

ISO 9002

CNC VERTICAL MILLING MACHINES

With "Mitutoyo" MillStar 2-Axis, 2 1/2-Axis & 3-Axis CNC

Mitutoyo's MillStar gives you everything you need to turn your manual mill into a high productivity moneymaker. Packages cover nearly every brand of manual mill made, and include:

- Power backup (30 minutes)
- Easy console switch from CNC to manual DRO
- High precision ballscrews for accurate positioning
- Heavy-duty servo motors capable of machining parts at rated capacity of machine
- 23" / LB DC servo motors
- CNC control runs on 110V AC power
- Mitutoyo linear glass scales for closed loop feedback
- 10.4" LCD color monitor, real-time graphics display, user-friendly touchpad
- Pentium processor, Windows® operating system
- All mounting hardware and G code editor

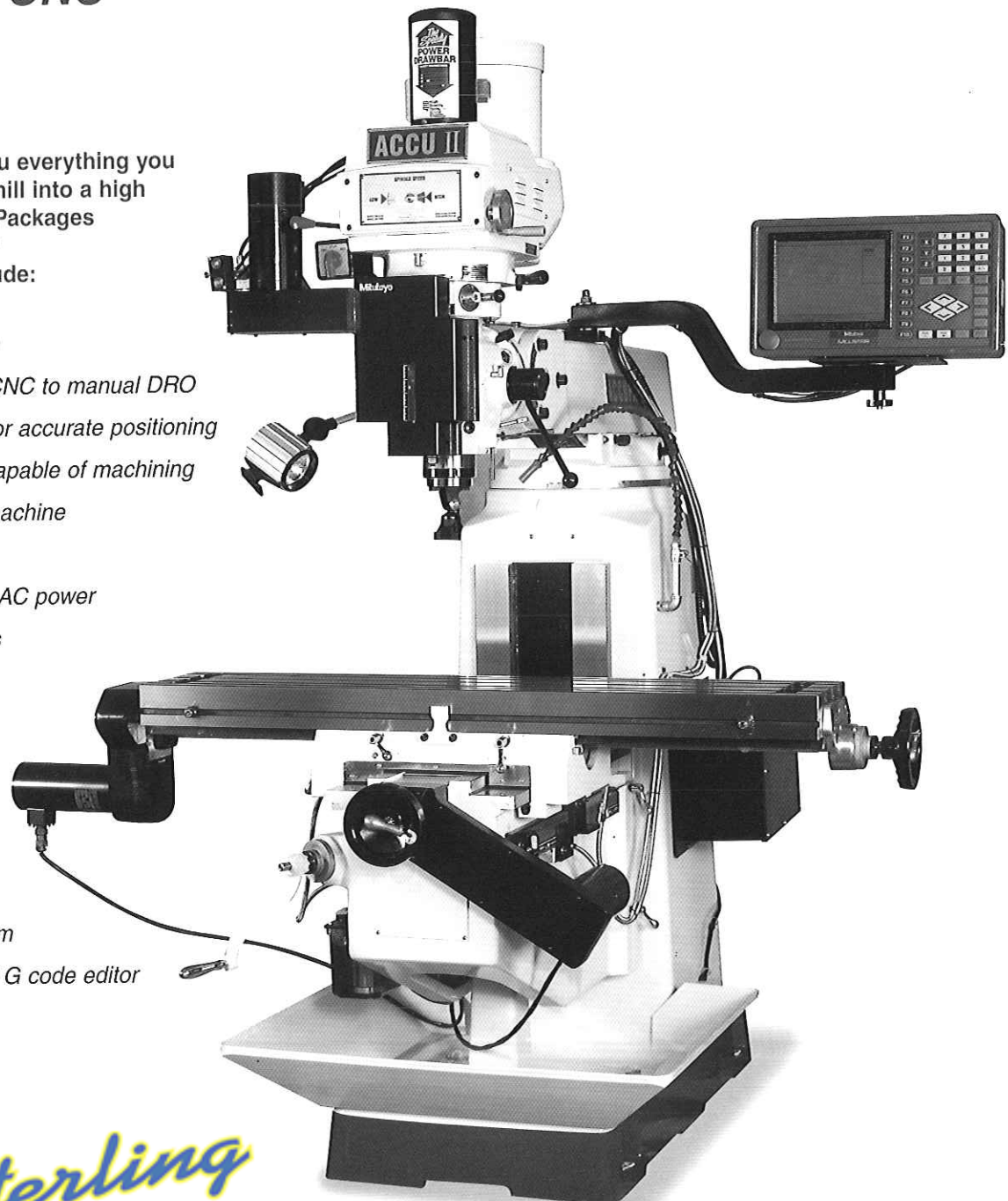

Sterling
MACHINERY EXCHANGE

www.SterlingMachinery.com

ACCU II CNC VERTICAL MILLING MACHINES

Mill Specifications:

MODEL	AC-2S	AC-2V	AC-3KV	AC-3KVF	AC-4KV	AC-4KVF
TABLE SIZE	9"x49"		10"x54"		10"x54"	
LONGITUDINAL TRAVERSE HAND ONLY	35"		36"		36"	
LONGITUDINAL TRAVERSE POWER FEED	32 1/4"		32 1/4"		32 1/4"	
CROSS TRAVEL	12"		15 3/4"		17"	
VERTICAL TRAVEL	16"		17"		17"	
QUILL FEEDS	0.0015",0.003",0.006"/REV		0.0015",0.003",0.006"/REV		0.0015",0.003",0.006"/REV	
QUILL TRAVEL	5"		5"		5"	
SPINDLE TAPER	R8		R8		NT#40 or CAT#40	
MOTOR	3HP		3HP		5HP	
SPINDLE SPEEDS (RPM)	90-5600-(16Speed)	70-4300(Vari)	60-4300(Vari)	50-5000(Vari)	60-4300(Vari)	50-5000(Vari)
NET WEIGHT	2200lbs	2250lbs	3000lbs		3700lbs	
A x B x C	85" x 64" x 67"		86" x 70 3/4" x 69"		90 1/2" x 81" x 72"	
D MAX	18"		18 3/4"		19 3/4"	
MIN	3"		3"		2"	
E MAX	12"		18"		18"	
MIN	0"		0"		0"	
F MAX	18 3/4"		24"		24"	
MIN	6 3/4"		6 3/4"		5 1/2"	
G MAX	22"		28"		28"	
MIN	8"		9"		10"	

Design and specifications are subject to change without notice.

Mitutoyo MillStar Control Features:

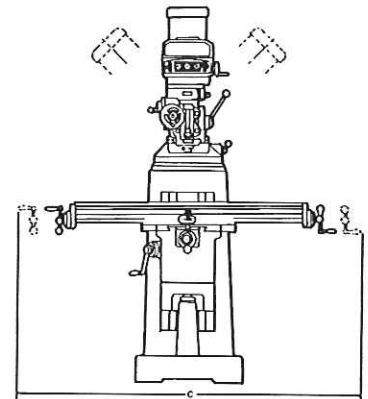
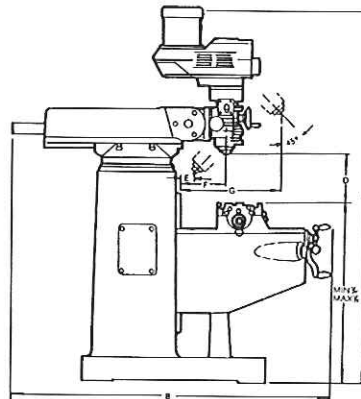
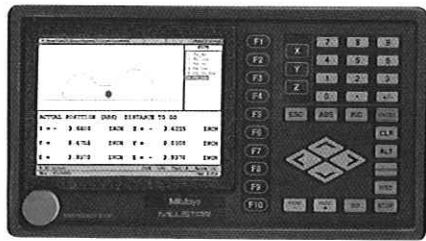

Drill

*Single / Line of holes at any angle / Grid of holes
Bore or Peck on 3-axis control*

Bolt Hole Pattern

*Complete / Incomplete
Bore or Peck on 3-axis control*

Line - Arc

*X-Y Polar / Corner radius / Advance line-arc
programming solves for unknown points*

Frame

*Circular / Rectangle / Rough and finish pass with
separate feed rates
3-axis include multiple Z pass to depth*

Pocket

*Circular / Rectangle / Irregular / Rough and
finish pass with separate feed rates / Advanced
programming solves for unknown points / Automatic
zig-zag section / Variable step over / Imports and
creates a pocket from previous line-arc programs
3-axis includes multiple Z passes to depth*

Special

*Repeat / Rotate / Mirror / Copy / Swap Grade
programming at control
Full 3-axis contouring with G-Code on 3-axis
control*

STANDARD ACCESSORIES:

- Toolbox
- Manual draw bar
- Front chip guard
- Rear chip guard
- Auto lubrication system
- * Auto lubrication system
- * 2-axis CNC for X/Y axis
- * 2 1/2-axis CNC for X/Y axis plus
Z axis DRO on quill
- * 3-axis CNC for X,Y,& Z axis on quill

OPTIONAL ACCESSORIES:

- Coolant system
- 6" anglock vise
- Halogen work light
- Power air draw bar
- Knee up/down power feed
- * Clamping kit & collets
- * Chip coolant drop pan
- * 4th axis rotary table package
- * CENTROID M15 CNC CONTROL
- * NT# 40 OR CAT# 40 TOOL holders

DISTRIBUTOR:

www.SterlingMachinery.com

